

TOLERANCES UNLESS OTHERWISE SPECIFIED :
 0~10±0.15、10~20±0.2、20~40±0.25、
 40~70±0.3、≥70±0.4

RHTECP NINGBO RHT ELECTRONIC CO.,LTD

UNITS:mm	SHEET SIZE: A4			SCALE:---	DRWN BY PAN
0~3	3~18	18~50	50~120	CHK'D BY FENG	
±0.12	±0.15	±0.3	±0.5	APPR BY ZHAN	

Modular Jack with transformer
 THIRD ANGLE PROJECTION
 RHTLYL008

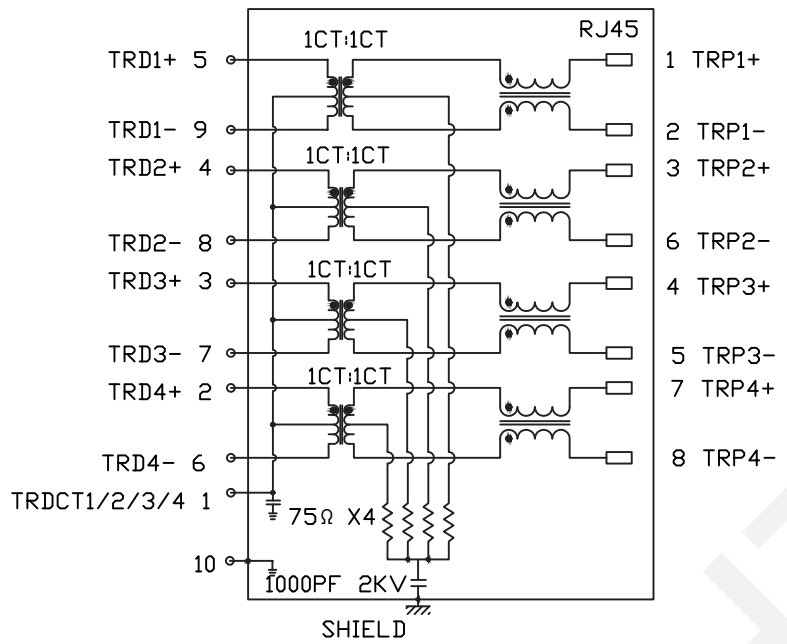

SPECIFICATIONS

CURRENT RATING: 1.5A
 VOLTAGE RATING: 125V AC
 INSULATION RESISTANCE: 500MΩ Mini
 WITHSTAND VOLTAGE: AC 1500 V RMS 50Hz OR 60Hz 1 Min
 CONTACT RESISTANCE: 20mΩ Max

INSERTION FORCE:
 2 CONTACT-----350g
 4 CONTACTS-----500g
 6 CONTACTS-----750g
 8 CONTACTS-----900g
 10 CONTACTS-----1050g

RETENTION STRENGTH: 7.7Kg BETWEEN JACK AND PLUG
 DURABILITY: 750 MATING CYCLES Mini

HOUSING:

- 1) GLASS FILLED PA66 (UL 94V-0)
- 2) GLASS FILLED PA46 (UL 94V-0)
- 3) GLASS FILLED PBT (UL 94V-0)

SPRING WIRE:

- 1) 0.45mm DIA PHOSPHOR BRONZE GOLD PLATING OVER NICKEL
- ALLOY SELECTIVE GOLD PLATING OVER NICKEL

SHIELDING: 0.24mm THICKNESS COPPER ALLOY WITH TIN PLATED
 GOLD PLATING: 3μ", 6μ", 15μ", 30μ", 50μ"

WORKING TEMPERATURE: -40°C~70°C

ELECTRICAL SPECIFICATIONS AT 25

Insertion Loss dB max	Return Loss dB min			Crosstalk(dB TYP)			Common Mode Rejection (dB TYP)		Hipot (vrms)
	1-30MHz	30-60MHz	60-80MHz	1-30MHz	30-60MHz	60-80MHz	1-50MHz	50-150MHz	
-1.0	-18	-16	-12	-40	-35	-30	-30	-20	1500

RHTECP NINGBO RHT ELECTRONIC CO.,LTD

UNITS:mm	SHEET SIZE: A4	SCALE:---	DRWN BY PAN
0~3	3~18	18~50	50~120
±0.12	±0.15	±0.3	±0.5
CHK'D BY FENG		APPR BY ZHAN	

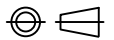
Modular Jack with transformer
 THIRD ANGLE PROJECTION

 RHTLYL008