

Notes:

1.Cage: Copper Alloy Thickness:0.25mm

2.Clip: Stainless Steel

3.Light Pipe: Polycarbonate Color Clear

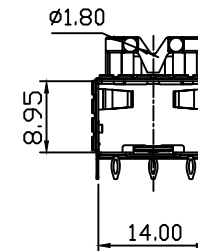
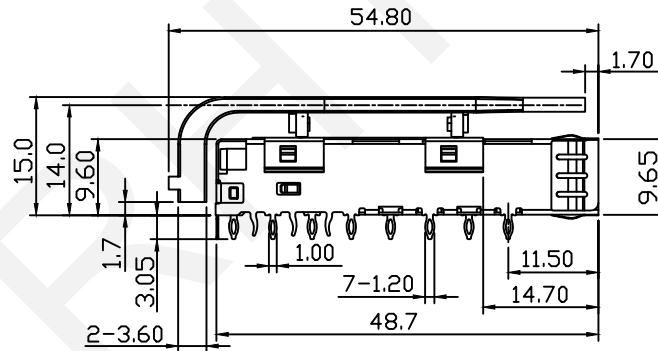
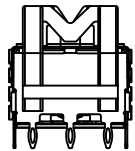

 NINGBO RHT ELECTRONIC CO.,LTD

UNITS:mm	SHEET SIZE: A4			SCALE:---
0~3	3~18	18~50	50~120	
±0.12	±0.15	±0.3	±0.5	

DRWN BY PAN  
CHK'D BY FENG  
APPR BY ZHAN

Crimping with transparent column

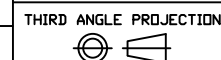

RHTLYFP-011A

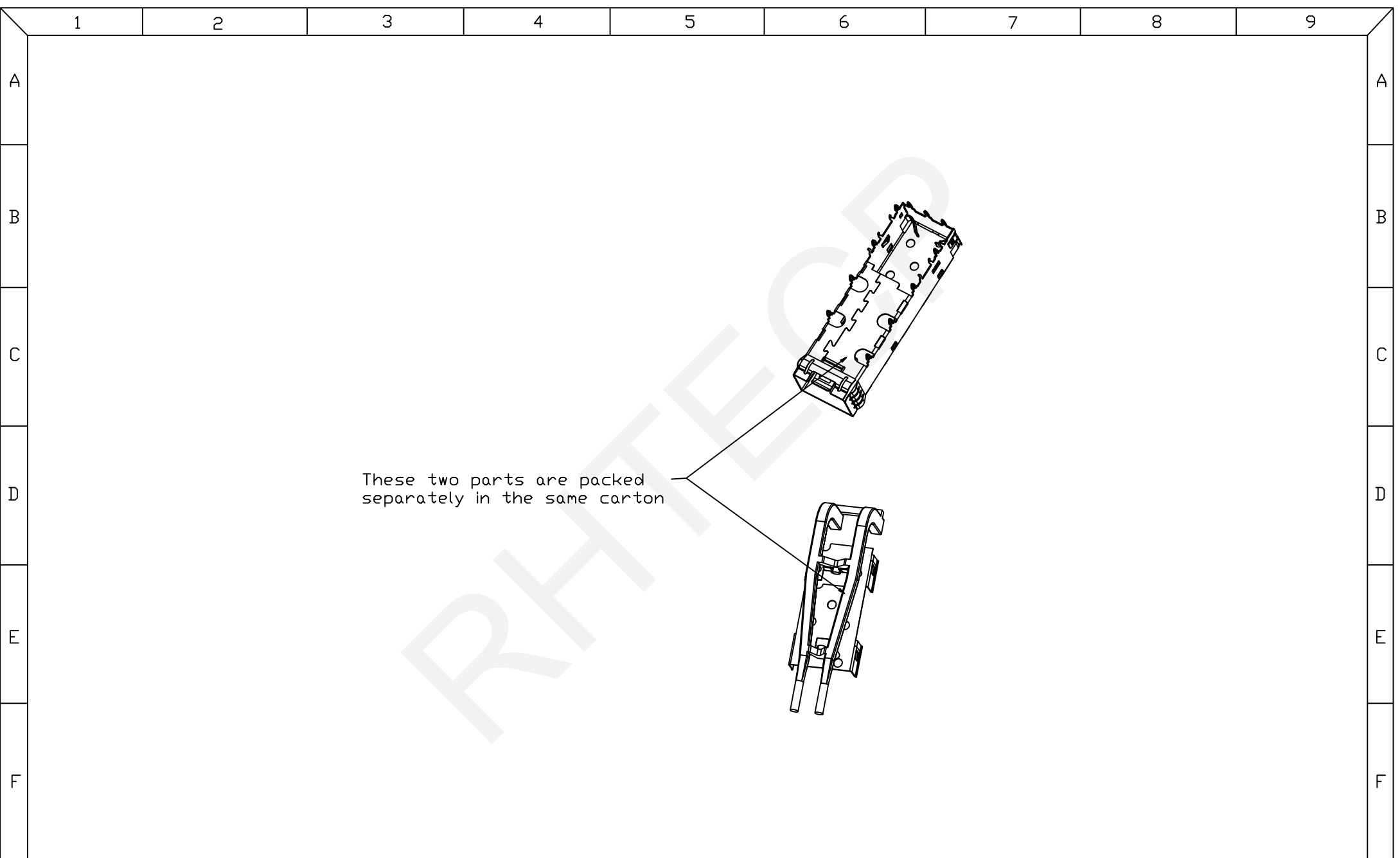

These two parts are packed separately in the same carton



NINGBO RHT ELECTRONIC CO.,LTD

UNITS:mm	SHEET SIZE: A4			SCALE:---
0~3	3~18	18~50	50~120	
±0.12	±0.15	±0.3	±0.5	

DRWN BY PAN  
CHK'D BY FENG  
APPR BY ZHAN

Crimping with transparent column

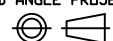
THIRD ANGLE PROJECTION 

RHTLYFP-011A

G 1 2 3

4 5

6

7

8

9 G

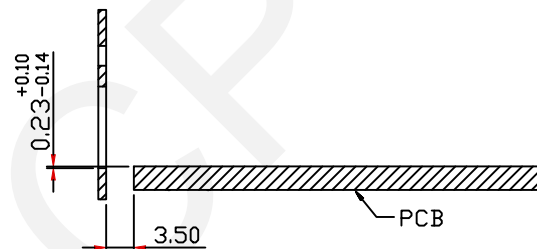
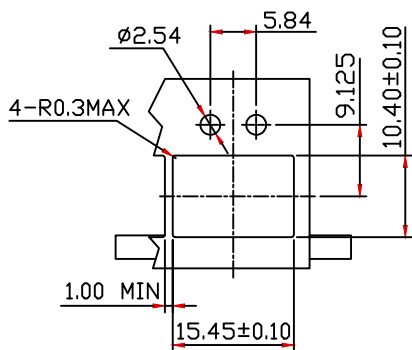

Bezel  
Recommended Panel Cutout And PC Board  
Panel Position And Thickness 0.8-2.6

Bezel Opening  
Below Top of PCB

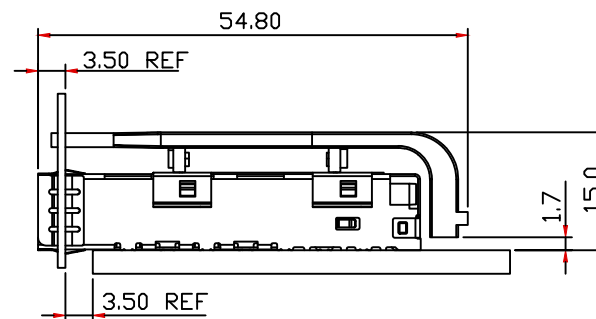
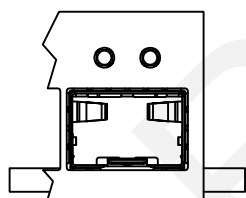

 NINGBO RHT ELECTRONIC CO.,LTD

UNITS:mm	SHEET SIZE: A4			SCALE:---
0~3	3~18	18~50	50~120	
±0.12	±0.15	±0.3	±0.5	

DRWN BY PAN  
CHK'D BY FENG  
APPR BY ZHAN

Crimping with transparent column

THIRD ANGLE PROJECTION  

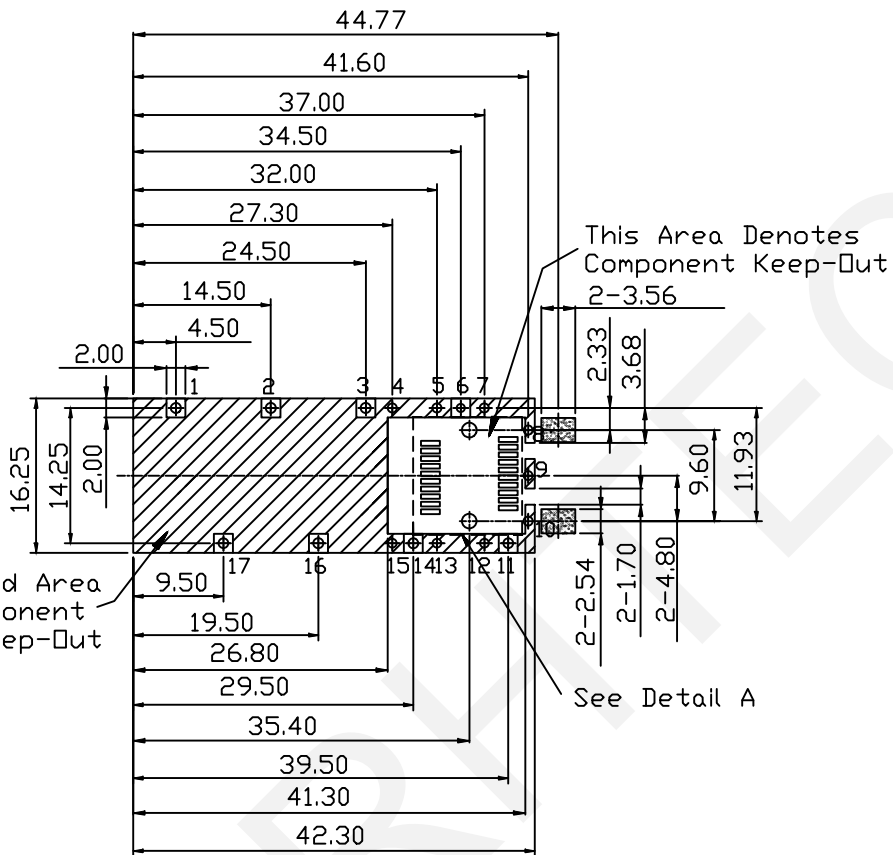

RHTLYFP-011A



Cross-Hatched Area  
Denotes Component  
And Trace Keep-Out

This Area Denotes  
Component Keep-Out  
2-3.56

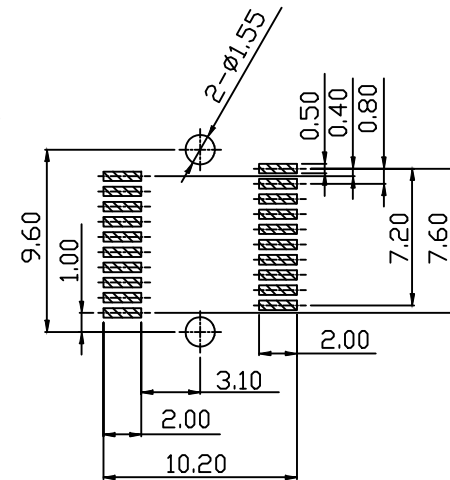
See Detail A



Detail A (Scale 2:1)

Note:

- 1,2,3,11,14,16,17# hole  $\phi 1.05\text{mm}$ ,
- 4,5,7,8,9,10,12,13,15# hole  $\phi 0.95\text{mm}$ ;
- 6# hole  $\phi 0.85\text{mm}$ ;

RECOMMENDED PCB LAYOUT(TOP VIEW)  
(ALL TOLERANCES ARE +0.05)

 NINGBO RHT ELECTRONIC CO.,LTD

UNITS:mm	SHEET SIZE: A4			SCALE:---
0~3	3~18	18~50	50~120	
±0.12	±0.15	±0.3	±0.5	

DRWN BY PAN  
CHK'D BY FENG  
APPR BY ZHAN

Crimping with transparent column

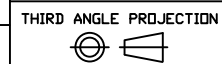

RHTLYFP-011A