

PANEL CUT-OUT

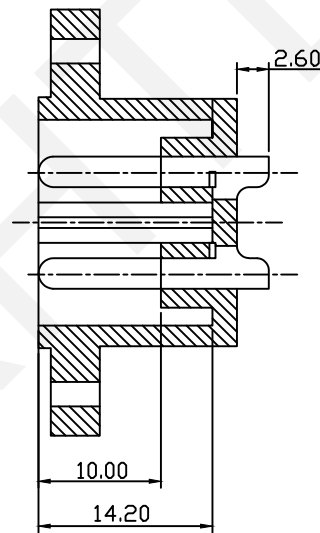
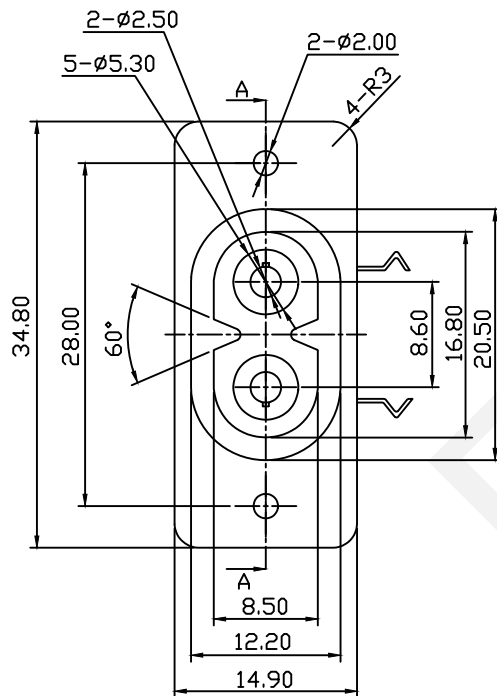

Section A-A

Notes:

1. Dielectric Strength: AC3000V~60Sec Between Poles
2. Insulation Resistance: Between Poles By DC500V Min 1000MΩ
3. Contact Resistance: Attached To Power Connect Or Max 50mΩ at 10A
4. Heat Resistance: 100±5°C for 1hr
5. Forming Strength Of Contact And Body: Static Load Of 10 Pounds/60sec
6. Strength Of Screw Clamping: Rotational Torque Of 0.8kg/cm.5Sec
7. Impact Test: 0.5kg 1 Times According To IEC950
8. Rating: 250V AC 10A(2.5A)

 NINGBO RHT ELECTRONIC CO.,LTD

UNITS:mm	SHEET SIZE: A4			SCALE:---
0~3	3~18	18~50	50~120	
±0.12	±0.15	±0.3	±0.5	

DRWN BY PAN  
CHK'D BY FENG  
APPR BY ZHAN

CAT5E UTP 8P8C Keystone Jacks

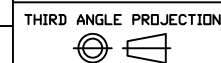

RHTLYK8101-8P8C