

**SPECIFICATION**

1. Rating : DC 30V 1.0A;
2. Contact resistance:  $\leq 0.03 \Omega$ ;
3. Insulation resistance:  $\geq 100M \Omega$  (DC250V);
4. Withstand voltage: 500VAC ;
5. Insertion and extraction force: 3-20N;
6. life test: 5,000 cycles.

**SCHEMATIC**

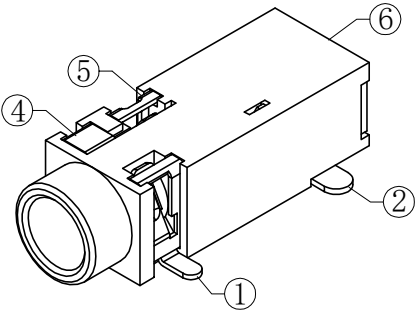
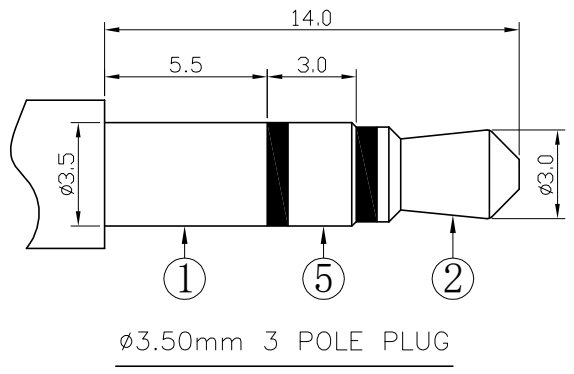
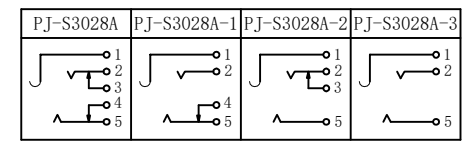

6	HOUSING	1	PA9T	
5	5# CONTACT FOOT	1	SUS301	Ag-Plating
4	4# CONTACT FOOT	1	BRONZE	Ag-Plating
3	3# CONTACT FOOT	1	BRASS	Ag-Plating
2	2# CONTACT FOOT	1	BRONZE	Ag-Plating
1	1# CONTACT FOOT	1	SUS301	Ag-Plating
NO.	DESCRIPTION	QTY	MATERIAL	PLATING

UNIT:MM	TYPE:	MODEL NO:	PAPER NO: A4	PAGE 1 OF 1	
	PHONE JACK	RE-C-PJ-S3028A	TOLERANCE	ANGLES	SCALE
			±0.15	±1.5°	4:1
				VER	1

DESIGNER BY: \_\_\_\_\_  
 CHECK BY: \_\_\_\_\_  
 APPROVED BY: \_\_\_\_\_

**RHTECP** NINGBO RHT ELECTRONIC CO.,LTD